

DISTRIBUTED BUS DIFFERENTIAL RELAY BECOMES THE COMPLETE INTEGRATED PROTECTION SYSTEM FOR THE SUBSTATION

Authors

J. Amantegui

IBERDROLA, Spain

R. Quintanilla

ZIV Aplicaciones y Tecnología, S. A. Spain

ABSTRACT

From the beginning, function integration has been one of the major motors for the evolution and innovation of the protection and control of electrical power systems. Developments in digital technology in recent years have driven integration non-stop, past the point of no return. Ample processing power makes the integration of every function possible, based on a common set of information and designed to actuate over the same set of components in the power system.

Optimizing costs, simplifying systems, and achieving a high level of standardization are the three most obvious advantages of integration. Nevertheless, there are other critical factors that cannot be overlooked. Such factors are very important in the protection and control systems of key installations, such as power systems: How does integration affect system and equipment reliability? What factors have to be considered regarding functional and physical redundancy?

Nowadays, digital technology has been proven as reliable and suitable for the design of protection systems and equipment. Intensive communications development came hand-in-hand with digital technology application, becoming one more component in the new system. The basic components of the new substation are protection IEDs, control IEDs, integrated protection and control IEDs, and substation central units from one or several manufacturers. The system topology is distributed in the most convenient arrangement using digital communication networks to integrate the different functions. It is in this architecture where the protection and control IED emerges to capture all the digital and analog information required for the protection, monitoring, and supervision of a substation bay.

Bus differential protection has been the last application to incorporate digital technology, due to its significant responsibility. The nature of bus differential protection sets it apart from other applications. In many schemes, this protection requires auxiliary elements to capture the currents necessary for operation. Today, the trend is changing as witnessed by existing digital bus differential

systems with several years of field operation on their resume. Several designs are based on distributed architecture schemes where bay IEDs capture and transmit the measured values and signals to a central unit responsible for calculating the differential protection algorithms. Such algorithms can be dynamically adaptive to the different substation topologies using the information received from the different bays.

There is a real junction, in terms of usage of information, between integrated protection and control IEDs and the bay IEDs of a bus differential protection.

This technical work describes the next step in function integration: the development and application of an Integral Bay Protection and Control IED. This design blends the bay protection functions with additional functions to make it part of a bus differential protection system. The paper analyzes the requirements to create such an Integral Protection and Control IED, from both a hardware and software point of view. Furthermore, the paper describes the design and characteristics of bus differential systems based on the design principles outlined.

The paper also discusses the reliability aspects to be considered, as well as the advantages from the proposed solution. The reliability chapter details the redundancy issues to be maintained, depending on the levels of importance and responsibility of each installation.

INTRODUCTION

There are several factors contributing to function integration in substation protection and control IEDs. Without a doubt, a key factor is the cost reduction that integration introduces. Such cost reduction not only includes the IEDs but every other system component affected by the integration, such as:

- IEDs and instrumentation
- Engineering and wiring
- Space (switchgear, cabinets, panels, etc.)
- Maintenance

Digital technology and communications have made extensive function integration successful for quite a number of years. Traditionally, protection and control systems (monitoring and control) were separate applications, with different technology and operation. Today both functions can be integrated in a single IED, being at once, a bay protection unit, a remote control terminal, and a local control panel.

The evolving pace towards integration varies among electrical utilities, and there are cases where such pace varies within a company. Voltage level, hierarchy of the installation in the system, or operation philosophy, are factors determining the need for protection and control integration.

Nevertheless, technology keeps evolving, making available to the designer possibilities exceeding the established reliability criteria.

- Double protection for transmission networks, based in the same or different schemes.
- Independent protection and control.
- Dedicated bus differential protection units without other protection functions nor control functions.

BUS DIFFERENTIAL PROTECTION

Criteria determining the independence of the bus differential system, applied to critical installations of major responsibility, can be directly linked to the high cost of purchasing, installing, and commissioning such systems in the past. Digital technology makes possible to change those criteria.

Some of the factors contributing to the change:

- Lower cost of the equipment.
- Distributed architecture places the analog current acquisition closer to the transducers secondary, reducing the complexity and cost of the wiring.
- No need for auxiliary transformers.
- Inclusion of the adaptive logic for system topology changes, based on the disconnecting switches status.
- No need for dedicated current transformers, using the same transformers as the other protections.

The cost reduction justifies the application of protection differential in substations with lower voltage levels (down to 45 kV or even 30kV).

Transmission system substations (132 kV to 400 kV) are fitted with bus differential protection to guarantee the stability conditions of the electrical system

In case of bus faults, selective and fast trips are required (below 100 ms).

In general, the system stability is not affected by faults in busses of lower voltage level (30 kV - 45 kV - 66 kV). The limits are given by criteria to prevent or limit the physical damage or destruction to the bus and substation apparatus. Fault clearance times are far above those for higher voltage substations (1.5 s).

Bus differential protection is fully justified at high voltage substations, despite its elevated cost. At medium voltage substations the cost of traditional bus differential systems is difficult to justify.

New bus differential digital designs, with distributed architecture, and without dedicated transformers or auxiliary transducers, bring the cost down making worth to consider its application to medium voltage substations.

BUS DIFFERENTIAL PROTECTION AND BAY PROTECTION INTEGRATION

This article presents one more step in the extensive application of digital technology. Present technology makes the compromise between advantages versus cost to balance towards the application of dedicated bus differential systems. The solution which eliminates such compromise is the combination, in a single IED, of the bay protection functions with the current magnitudes acquisition to be used in a bus differential system.

There are cases where the medium voltage electric system is a dense grid. A bus fault or a line fault improperly cleared by the breaker failure, creates trips in lines and/or adjacent or nearby busses which magnify the problem. Such conditions could unnecessary blackout large areas. These situations should be avoided due to the economic consequences and the decrease on the quality of service perceived by the utility's customers.

Medium voltage substations have busses with high short circuit power. Long fault clearing times increases the possibility of damage to the substation apparatus.

Selectivity and fast operation times are requirements, even for medium voltage installations. Low cost solutions that address such requirements are needed to provide high system reliability. Combining the bus differential functions with the bay protection is the technical solution to the problems described.

Traditional protective systems, even in double bus substations, require to trip every bay under bus faults. A bus differential system in the substation enables to clear the faulted bus and to keep in service the second bus.

In installations with schemes other than single bus, the bus protection requires to capture the status of the disconnecting switches to determine the substation topology. Since this information is also required in the supervisory and control system, it makes sense to merge both systems, protection and control, including supervision functions, control, automatic functions, interlocks, etc.

Other information available to this combined system is apparatus status, protection system data, current metering values, etc. All these information enable the user to create high speed automatic functions (operating times similar to those of the protective functions). Complexity of the automatic functions vary from difficult, as in voltage restoration schemes; to easy, as in a settings group change depending on the system conditions.

RELIABILITY ISSUES

Different installations have different reliability requirements based on the voltage level or importance within the system. Physical redundancy and security issues contribute to such reliability, such as application of several main protections.

To achieve a successful solution, the proposed system should address every requirement in the installation. The following description of the design and architecture shows the bus differential system flexibility, needed to reach the reliability goal.

DESIGN AND ARCHITECTURE

The physical architecture of the system requires a design applicable to both concentrated and distributed solutions. A distributed architecture with bay IEDs and a central unit, that also offers compact installation, is the solution adaptable to both cases.

Protection functions should include bus differential, directional overcurrent, and distance or line differential. The user should be able to select double protection scheme with the same or different principles.

The system should include local control functions, in the same platform or in a separate platform, depending on the reliability and safety requirements.

The design should also provide flexibility in the communication system to be used, depending on the system or user needs.

The solution proposed in this work covers every design requirement proposed. The components are:

1. Protection and control bay IED. Includes communication functions to send the analog and digital data to the differential central unit. This IED has been designed to have all the functions available in the same unit or in modular units linked by communications.
2. Fiber optic communication network with star topology and protocol designed for the transfer of digital and analog data. Capable of additional channels to use the IED as a remote control unit.
3. Differential central unit, as a platform for the bus differential algorithms and optionally for additional logic units.

Bay Unit

Figure 1 shows the block diagram for the bay IED.

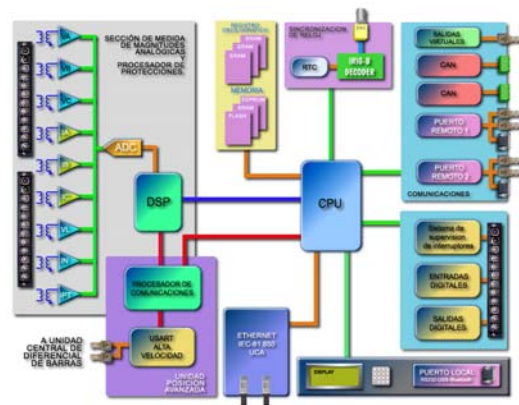

Figure 1 . Bay IED block diagram

The bay unit includes characteristics for operations as a protection unit (bay and bus protection) and/or control (supervision, local and remote control), according to the generic diagrams show in figures 2 and 3.

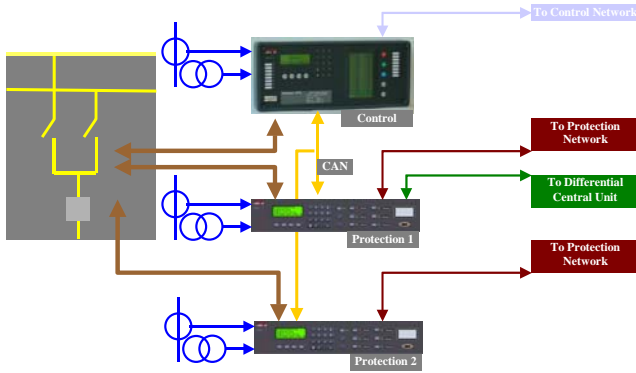

Figure 2. Independent protection and control

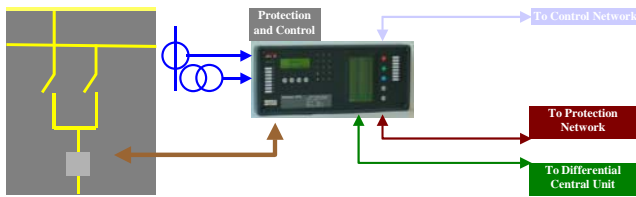

Figure 3. Integrated protection and control

Central Differential Unit

This unit processes the samples received from the bay IEDs. The data is used by the differential protection algorithms which detect bus fault conditions. Under fault conditions the topology of the substation, also received from the IEDs, determines the breakers to be tripped to clear the fault.

The central unit includes characteristics enabling it to perform other important functions: substation-wide automatic controls and capabilities to become the key of the substation communication network between levels 1 and 2.

Communication Network

The differential protection uses a fiber optic communication network. The main function is to exchange data between the central unit and bay IEDs: metering samples and apparatus status towards the central unit, and trip and breaker failure initiate towards the bay IEDs.

Also, the proposed design includes an additional communication function enabling a further step towards integration. The communication architecture of a distributed bus differential protection is a star system same as in a integrated protection and control system. In the former case, the differential unit is the center of the

star, where in the later case the center is the substation central unit.

Completing the total integration mentioned, is possible to integrate the differential data acquisition functions with other protection and control functions in the bay IED.

Next it makes sense to integrate both communication networks, even when the differential central unit and substation central unit functions remain independent.

Figure 4 shows the system architecture described.

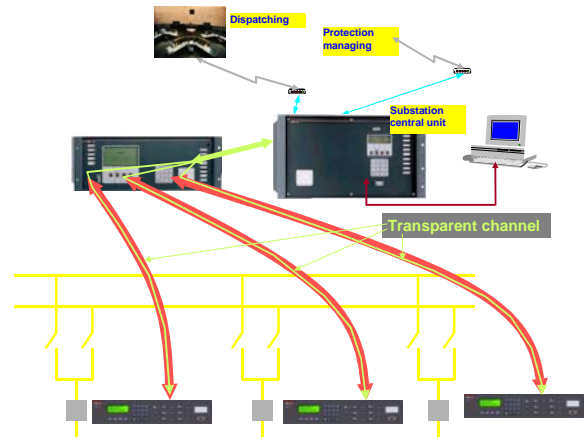

Figure 4. Integrated communications

In the figure, the three communication networks, bus differential, protection and control are merged in a single network. Distributed bus differential systems are designed with a 1 Mbps communication network. Such rate offers enough bandwidth to transfer the differential current samples, 64 samples per cycle (per phase and per bay), plus a transparent channel to integrate the other two networks (monitoring, status, metering, commands, IED setting, file collection for oscillography, events, etc...).

The IED design includes a set of communication ports, making possible to arrange them in other network architectures. Networks with lower level of integration are possible, depending on the redundancy requirements established by the user or the application. Figure 5 depicts an application with 3 independent communication networks.

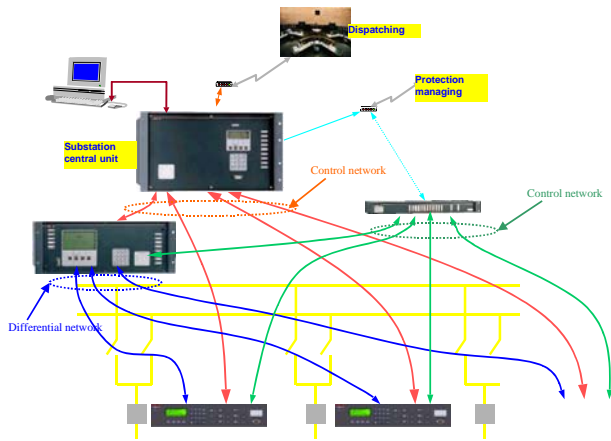

Figure 5. Independent Communications

Differential Central Unit

This unit processes the samples received from the bay IEDs. The data is used by the differential protection algorithms which detect bus fault conditions. Under fault conditions the topology of the substation, also received from the IEDs, determines the breakers to be tripped to clear the fault.

The central unit includes characteristics enabling it to perform other important functions:

- Become on the center of the star communication network existing between levels 1 and 2 of the substation.
- Since all the information regarding apparatus status, and level 1 IEDs functions is received, the central unit can become the platform for substation-wide automatic controls with operating times faster than those functions present in a substation central unit.
- Based on all the information available, the differential central unit can become a complete substation oscillography recorder as well as DFR, including data from every single function installed in the substation.

CONCLUSIONS

Integrated protection and control bay IEDs can become bus differential bay IEDs with a moderate increase in cost.

On the other hand, distributed bus differential architecture offers the base to merge every protection and control functions needed in a substation, including communications.

The convergence of both facts, enable the creation of a complete protection and control system. A system offering flexibility to the user and the application to determine the level of integration depending to the reliability, safety, and physical redundancy requirements