



# PMUs Applications of the Spanish Transmission System Operator

**S. López**

**Red Eléctrica de España**

**J. Gómez**

**Red Eléctrica de España**

**R. Cimadevilla**

**ZIV P+C**

**O. Bolado**

**ZIV USA**



# Overview

- Line impedances calculation
- Fault location on mixed lines
- Oscillations monitoring



# Line Impedances Calculation



# Impedances Calculation

- Traditional methods can give important errors → incorrect settings for distance relays, fault locators, etc
  - **Z1 Calculation:**
    - *Resistance of conductors / ground wires:*
      - Varies with temperature / load flow
    - *Geometrical parameters:*
      - Vary along the line → *average value*
  - **Z0/Z0M Calculation:**
    - *Distance from conductors to ground: average value*
    - *Ground resistance*
    - *Ground resistivity:*
      - Earth non-homogeneous
      - Varies with temperature, humidity
      - Buried elements (cables, pipes...)



# Impedances Calculation with PMUs



## ■ Positive Sequence Impedance

- Can be calculated at any time
- Requires positive sequence measurements at both ends of the line

## ■ Zero Sequence Impedance

- Can only be calculated when there is zero sequence flow
- Requires zero sequence measurements at both ends of the line

## ■ Zero Sequence Mutual Impedance

- Also requires zero sequence measurements at both ends of the parallel line

## ■ Impedance variations suggest periodic calculations (use of *different setting groups*)

# Z1 Calculation (load conditions)

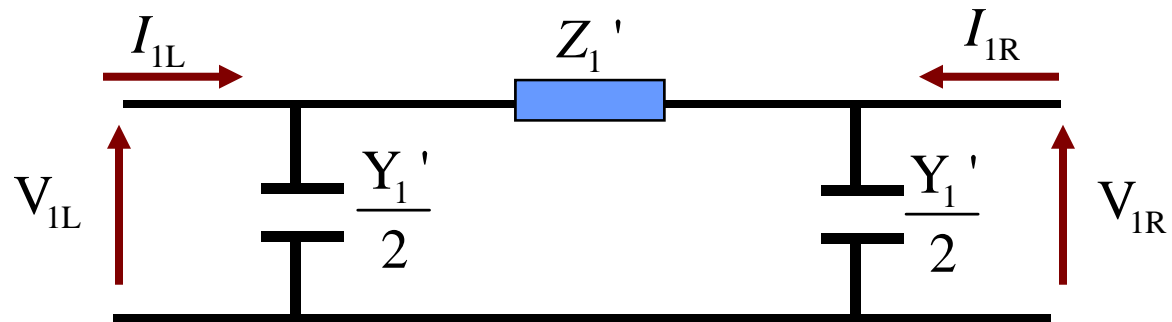

Short / medium lines:

$$\left. \begin{aligned} V_{1R} &= V_{1L} - (I_{1L} - V_{1L} \cdot \frac{Y_1'}{2}) \cdot Z_1' \\ -I_{1R} &= I_{1L} - V_{1L} \cdot \frac{Y_1'}{2} - V_{1R} \cdot \frac{Y_1'}{2} \end{aligned} \right\} \longrightarrow \begin{cases} Y_1' = 2 \cdot \frac{I_{1L} + I_{1R}}{V_{1L} + V_{1R}} \\ Z_1' = \frac{V_{1L}^2 - V_{1R}^2}{I_{1L} \cdot V_{1R} + I_{1R} \cdot V_{1R}} \end{cases}$$

Long lines:

$$\left. \begin{aligned} V_{1R} &= V_{1L} \cdot ch(\gamma_1 \cdot L) - I_{1L} \cdot ZC_1 \cdot sh(\gamma_1 \cdot L) \\ -I_{1R} &= I_{1L} \cdot ch(\gamma_1 \cdot L) - \frac{V_{1L}}{ZC_1} \cdot sh(\gamma_1 \cdot L) \end{aligned} \right\} \longrightarrow \begin{cases} ZC_1 = \sqrt{\frac{z_1}{y_1}} = \frac{V_{1L}^2 - V_{1R}^2}{\sqrt{(V_{1R}^2 - V_{1L}^2) \cdot (I_{1R}^2 - I_{1L}^2)}} \\ \gamma_1 = \sqrt{z_1 \cdot y_1} = ch^{-1} \left( \frac{-V_{1L} \cdot I_{1L} + V_{1R} \cdot I_{1R}}{V_{1L} \cdot I_{1R} - V_{1R} \cdot I_{1L}} \right) \cdot \frac{1}{L} \end{cases}$$

# Z0 Calculation (external ground fault)

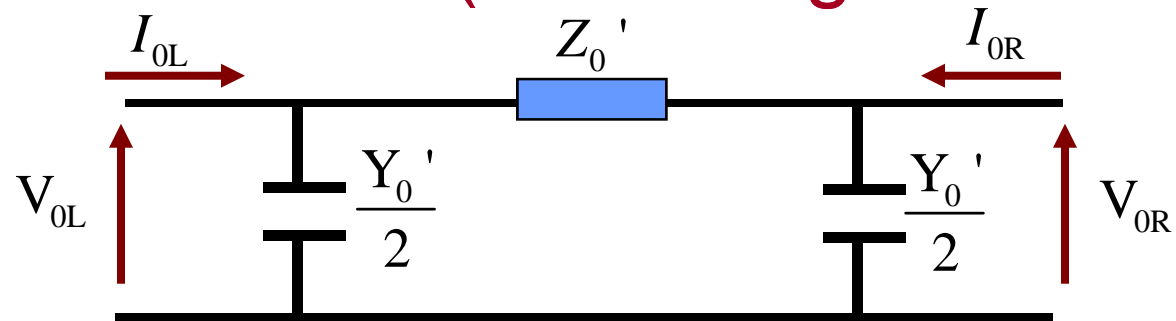

Short / medium lines:

$$\left. \begin{aligned} V_{0R} &= V_{0L} - \left( I_{0L} - V_{0L} \cdot \frac{Y_0'}{2} \right) \cdot Z_0' \\ -I_{0R} &= I_{0L} - V_{0L} \cdot \frac{Y_0'}{2} - V_{0R} \cdot \frac{Y_0'}{2} \end{aligned} \right\} \longrightarrow \left\{ \begin{aligned} Y_0' &= 2 \cdot \frac{I_{0L} + I_{0R}}{V_{0L} + V_{0R}} \\ Z_0' &= \frac{V_{0L}^2 - V_{0R}^2}{I_{0L} \cdot V_{0R} + I_{0R} \cdot V_{0L}} \end{aligned} \right.$$

Long lines:

$$\left. \begin{aligned} V_{0R} &= V_{0L} \cdot ch(\gamma_0 \cdot L) - I_{0L} \cdot ZC_0 \cdot sh(\gamma_0 \cdot L) \\ -I_{0R} &= I_{0L} \cdot ch(\gamma_0 \cdot L) - \frac{V_{0L}}{ZC_0} \cdot sh(\gamma_0 \cdot L) \end{aligned} \right\} \longrightarrow \left\{ \begin{aligned} ZC_0 &= \sqrt{\frac{z_0}{y_0}} = \frac{V_{0L}^2 - V_{0R}^2}{\sqrt{(V_{0R}^2 - V_{0L}^2) \cdot (I_{0R}^2 - I_{0L}^2)}} \\ \gamma_0 &= \sqrt{z_0 \cdot y_0} = ch^{-1} \left( \frac{-V_{0L} \cdot I_{0L} + V_{0R} \cdot I_{0R}}{V_{0L} \cdot I_{0R} - V_{0R} \cdot I_{0L}} \right) \cdot \frac{1}{L} \end{aligned} \right.$$

# Z0M Calculation (external ground fault)

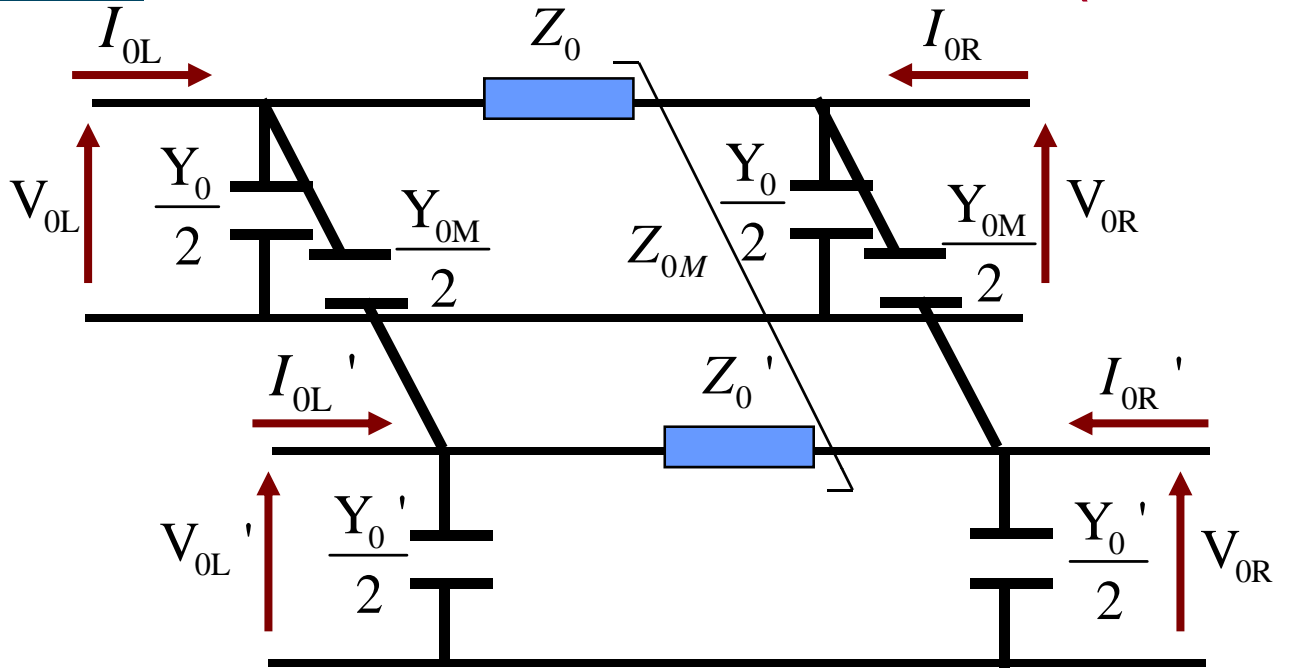

**6 unknowns**  
 ( $Z_0, Z_0', Z_{0M}, Y_0, Y_0', Y_{0M}$ )

**2 faults required!**

$$\begin{aligned}
 V_{0R} &= V_{0L} - \left[ I_{0L} - V_{0L} \cdot \frac{Y_0}{2} - (V_{0L} - V_{0L}') \cdot \frac{Y_{0M}}{2} \right] \cdot Z_0 - \left[ I_{0L}' - V_{0L}' \cdot \frac{Y_0'}{2} - (V_{0L}' - V_{0L}) \cdot \frac{Y_{0M}}{2} \right] \cdot Z_{0M} \\
 -I_{0R} &= I_{0L} - V_{0L} \cdot \frac{Y_0}{2} - (V_{0L} - V_{0L}') \cdot \frac{Y_{0M}}{2} - V_{0R} \cdot \frac{Y_0}{2} - (V_{0R} - V_{0R}') \cdot \frac{Y_{0M}}{2} \\
 V_{0R}' &= V_{0L}' - \left[ I_{0L}' - V_{0L}' \cdot \frac{Y_0'}{2} - (V_{0L}' - V_{0L}) \cdot \frac{Y_{0M}}{2} \right] \cdot Z_0' - \left[ I_{0L} - V_{0L} \cdot \frac{Y_0}{2} - (V_{0L} - V_{0L}') \cdot \frac{Y_{0M}}{2} \right] \cdot Z_{0M} \\
 -I_{0R}' &= I_{0L}' - V_{0L}' \cdot \frac{Y_0'}{2} - (V_{0L}' - V_{0L}) \cdot \frac{Y_{0M}}{2} - V_{0R}' \cdot \frac{Y_0'}{2} - (V_{0R}' - V_{0R}) \cdot \frac{Y_{0M}}{2}
 \end{aligned}$$



# RTDS Simulation

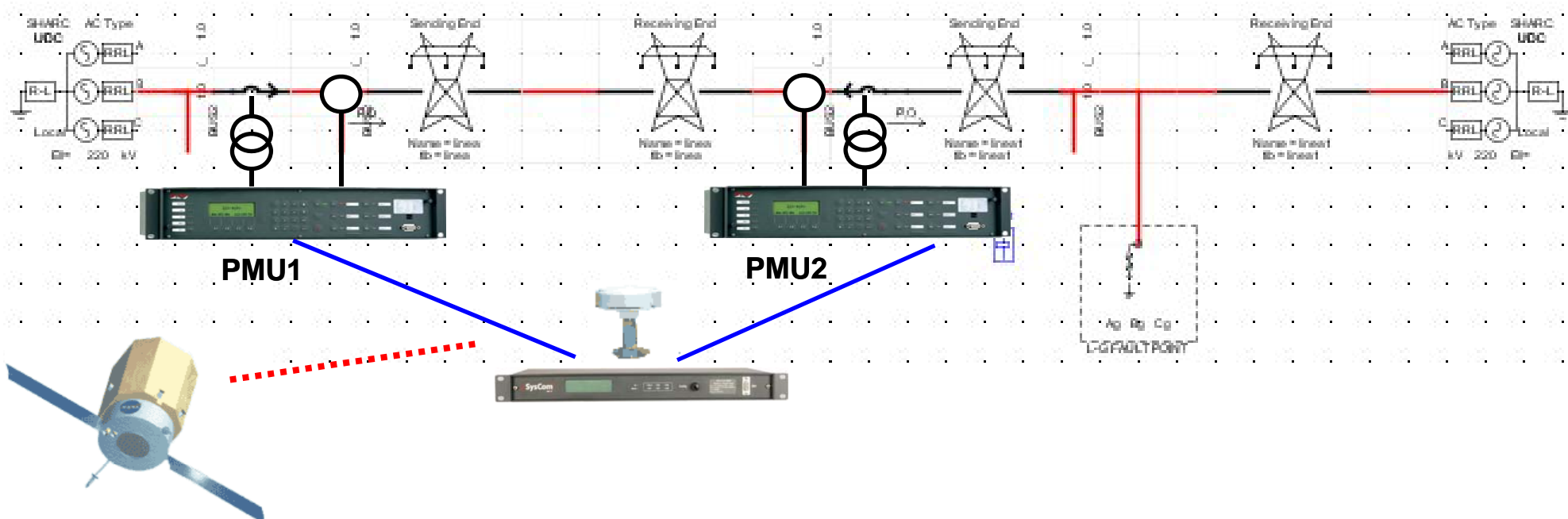

TYPE OF CIRCUIT	LENGTH	PARAMETERS
SIMPLE	L1=50 km	$z1 = 0.0717 + j \cdot 0.4135 \Omega/\text{Km}$ $z0 = 0.3029 + j \cdot 1.2471 \Omega/\text{Km}$
	L2=300 Km	$y1 = j \cdot 2.8 \mu\text{S}/\text{Km}$ $y0 = j \cdot 1.97 \mu\text{S}/\text{Km}$
DOUBLE	L3=100 km	$z0M = 0.25 + j \cdot 0.76 \Omega/\text{Km}$ $y0M = j \cdot 1.4 \mu\text{S}/\text{Km}$



# PMUs Features

- Distance protection + PMU
- 50 synchrophasors / sg (50 Hz)
- 1 cycle recursive DFT with 32 samples / cycle
- Frequency tracking: sampling depends on network frequency → remove errors at off-nominal frequencies

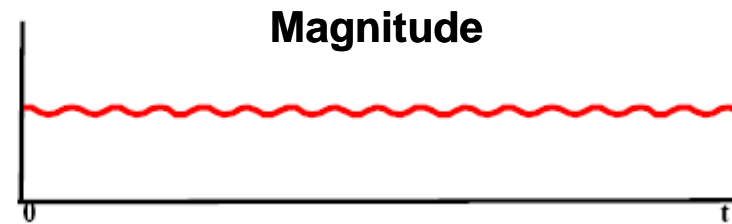
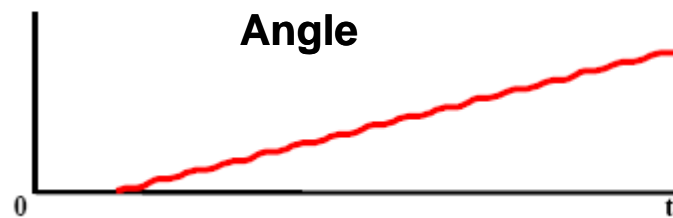

- Compensation between DFT cosine wave (maximum at coefficient  $n^0 0$ ) and GPS cosine wave (maximum at PPS)
- Antialiasing filters for interfering signals disabled

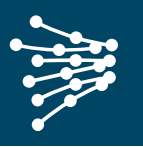

# Results with PMUs errors (TVE<1%)

## Positive sequence

LINE	ZSOURCE (ohms)	LOAD CURRENT	RESISTANCE ERROR	REACTANCE ERROR	ADMITTANCE ERROR
1	1	0.5 A	8.9%	0.62%	-13.21%
1	20	1.5 A	5.43%	-0.09%	-12.05%
2	1	0.5 A	3.8%	1.10%	3.37%
2	20	1.5 A	1.1%	0.77%	5.85%

## Zero sequence

LINE	FAULT TYPE	ZSOURCE (ohms)	LOAD CURRENT	FAULT RESISTANCE (ohms)	RESISTANCE ERROR	REACTANCE ERROR	ADMITTANCE ERROR
1	AG	1	0.5 A	50	1.25%	-0.53%	10.1%
1	BCG	20	1.5 A	10	2.5%	0.024%	-9.4%
2	AG	1	0.5 A	50	2.8%	2.3%	9.9%
2	BCG	20	1.5 A	10	0.17%	1.8%	-12.8%

## Mutual zero sequence

LINE	FAULT TYPE	ZSOURCE (ohms)	LOAD CURRENT	FAULT RESISTANCE (ohms)	MUTUAL RESISTANCE ERROR	MUTUAL REACTANCE ERROR	MUTUAL ADMITTANCE ERROR
3	AG	1	0.5 A	50	5.3%	2.8%	13.4%



# Synchronization Errors (I)

**10° error between currents**

POSITIVE SEQUENCE			
LINE	ADDITIONAL RESISTANCE ERROR	ADDITIONAL REACTANCE ERROR	ADDITIONAL ADMITANCE ERROR
1	67.14%	-1.97%	606.95%
2	60.34%	-2.94%	62.48%

ZERO SEQUENCE			
LINE	ADDITIONAL RESISTANCE ERROR	ADDITIONAL REACTANCE ERROR	ADDITIONAL ADMITANCE ERROR
1	70.27%	-4.87%	-1396.10%
2	80.05%	-5.07%	-49.31%

↓ 2.09%      **0.5° error**      ↓ 12.47%      **0.5° error**      ↓ 3.50%      **0.5° error**      ↓ 52.00%

- High accuracy in synchronization needed for resistance and admittance calculation → GPS
- Check the time quality included in the frames

# Synchronization Errors (II)

## 10° error between voltages

POSITIVE SEQUENCE				ZERO SEQUENCE			
LINE	ADDITIONAL RESISTANCE ERROR	ADDITIONAL REACTANCE ERROR	ADDITIONAL ADMITANCE ERROR	LINE	ADDITIONAL RESISTANCE ERROR	ADDITIONAL REACTANCE ERROR	ADDITIONAL ADMITANCE ERROR
1	44.00%	190.00%	-1.49%	1	6.06%	-0.26%	-4.83%
2	-30.04%	45.55%	3.76%	2	1.02%	-0.03%	-0.07%

**0.5° error**

21.79%	19.69%	0.28%	-0.24%
--------	--------	-------	--------

- Very high accuracy in synchronization needed for resistance and reactance calculation → GPS
- Check the time quality included in the frames



# Synchronization Errors (III)



- Positive sequence calculation based on pure fault values

## 10<sup>0</sup> error between voltages

LINE	ADDITIONAL RESISTANCE ERROR	ADDITIONAL REACTANCE ERROR	ADDITIONAL ADMITANCE ERROR
1	5.20%	-0.14%	-0.044%
2	0.85%	-0.02%	0.00%



# Current Transformer Errors 5P20 (I)

■ Error < 1% / 60 min at  $I_{nom}$ ; at  $20I_{nom}$  composite error < 5%

**+3%  $I_{local}$  / +3%  $I_{remote}$  for Z calculation**

**+3%  $I_{local}$  / -3%  $I_{remote}$  for Y calculation**

POSITIVE SEQUENCE			
LINE	ADDITIONAL RESISTANCE ERROR	ADDITIONAL REACTANCE ERROR	ADDITIONAL ADMITANCE ERROR
1	4.85%	-2.99%	35.76%
2	0.77%	-3.98%	6.39%

ZERO SEQUENCE			
LINE	ADDITIONAL RESISTANCE ERROR	ADDITIONAL REACTANCE ERROR	ADDITIONAL ADMITANCE ERROR
1	-2.94%	-2.91%	59.33%
2	-2.91%	-2.91%	53.90%

**+2°  $I_{local}$  / +2°  $I_{remote}$  for Z calculation**

**+2°  $I_{local}$  / -2°  $I_{remote}$  for Y calculation**

POSITIVE SEQUENCE			
LINE	ADDITIONAL RESISTANCE ERROR	ADDITIONAL REACTANCE ERROR	ADDITIONAL ADMITANCE ERROR
1	38.85%	-1.18%	-52.95%
2	36.72%	-2.09%	39.16%

ZERO SEQUENCE			
LINE	ADDITIONAL RESISTANCE ERROR	ADDITIONAL REACTANCE ERROR	ADDITIONAL ADMITANCE ERROR
1	22.88%	-1.33%	-634.74%
2	24.72%	-1.24%	-23.14%

■ **PMU calibration required!**



# Voltage Transformer Errors 3P (I)



■ Error < 3% / 120 min at 5%, 120%, 150% / 190% Unom

**+3%  $V_{local}$  / -3%  $V_{remote}$  for Z calculation**

**+3%  $V_{local}$  / +3%  $V_{remote}$  for Y calculation**

POSITIVE SEQUENCE			
LINE	ADDITIONAL RESISTANCE ERROR	ADDITIONAL REACTANCE ERROR	ADDITIONAL ADMITANCE ERROR
1	390.14%	-10.90%	-2.90%
2	105.34%	-3.66%	-0.35%

ZERO SEQUENCE			
LINE	ADDITIONAL RESISTANCE ERROR	ADDITIONAL REACTANCE ERROR	ADDITIONAL ADMITANCE ERROR
1	-3.57%	-3.47%	-2.92%
2	-3.07%	-3.07%	-2.92%

**+2°  $V_{local}$  / -2°  $V_{remote}$  for Z calculation**

**+2°  $V_{local}$  / +2°  $V_{remote}$  for Y calculation**

POSITIVE SEQUENCE			
LINE	ADDITIONAL RESISTANCE ERROR	ADDITIONAL REACTANCE ERROR	ADDITIONAL ADMITANCE ERROR
1	119.42%	29.47%	-1.26%
2	32.43%	26.23%	2.18%

ZERO SEQUENCE			
LINE	ADDITIONAL RESISTANCE ERROR	ADDITIONAL REACTANCE ERROR	ADDITIONAL ADMITANCE ERROR
1	26.26%	-1.55%	-21.63%
2	25.32%	-1.26%	-2.08%

■ **PMU calibration required!**



# Voltage Transformer Errors (II)



- Positive sequence calculation based on fault / pure fault values reduces the errors



# Fault Location on Mixed Lines



# Protection Scheme for Mixed Lines

- Great increase of mixed lines in Spain
- Underground section length  $\ll$  overhead section length  
→ recloser used
- No reclosing for faults in the cable!
  - Public Safety
  - Cable Life
- It is necessary to determine the faulted section



# First Protection Scheme

- Faults in the cable detected by two line differential relays installed at both ends of the cable
  - **Advantages:** Perfectly detects the faults in the cable
  - **Disadvantages:** High installation and maintenance costs (requires CTs, power supply...at both ends of the cable)



# Second Protection Scheme

- Faults in the overhead sections detected by two distance relays installed at both ends of the mixed line (specific zone to cover each overhead section)
  - **Advantages:** Much cheaper
  - **Disadvantages:**
    - Distance zones can not cover 100% of overhead sections due to possible overreach (*mixed loop, inaccuracies in  $Z_0$ , capacitance not considered, erroneous phase selection, load flow, system non-homogeneous ...*)
    - Prone to underreaching for very resistive faults



# Third Protection Scheme

- Second solution + fault locator based on PMUs
- Distance protection + PMU in the same device
- Fault locator information used for:
  - Manual Close (control center)
  - Reclose blocking (calculation time < reclose cycle)



# Fault Locator with PMUs (I)

- Only based on positive sequence network:
  - Avoids problems with the cable zero sequence impedance (variable depending on the return path)
  - Does not depend on fault resistance, load flow, system homogeneity
  - Does not require phase selection
- Uses circuits with distributed parameters
- Two algorithms tested:
  - **Algorithm 1**: Positive sequence fault values
  - **Algorithm 2**: Positive sequence pure fault values (removes prefault values)



# Fault Locator with PMUs (II)

- **Identification of the faulted section:** calculates distance to the fault ( $d$ : starting from one cable end), assuming that the fault is in the cable:
  - Si  $0 < d < 1$ : the fault is in the cable  $\rightarrow$  block reclosing
  - Si  $d < 0$ : the fault is in the 1<sup>st</sup> overhead section  $\rightarrow$  new  $d$  calculation
  - Si  $d > 1$ : the fault is in the 2<sup>nd</sup> overhead section  $\rightarrow$  new  $d$  calculation

# Circuit for Faults in the Cable

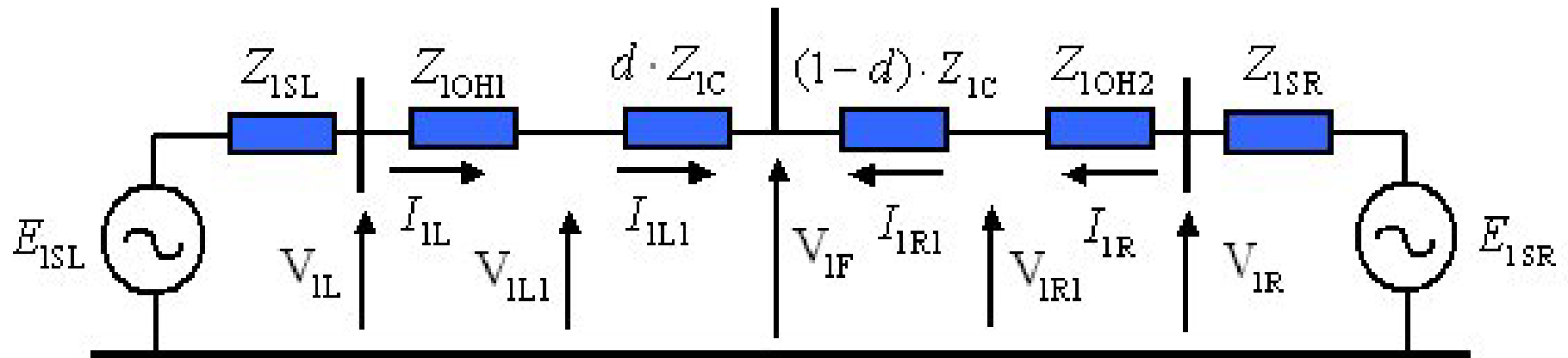

$$V_{1F} = V_{1L1} \cdot ch(\gamma_C \cdot d \cdot L_C) - I_{1L1} \cdot ZC_C \cdot sh(\gamma_C \cdot d \cdot L_C)$$

$$V_{1L1} = V_{1L} \cdot ch(\gamma_{L1} \cdot L_{L1}) - I_{1L} \cdot ZC_{L1} \cdot sh(\gamma_{L1} \cdot L_{L1}) \quad I_{1L1} = I_{1L} \cdot ch(\gamma_{L1} \cdot L_{L1}) - \frac{V_{1L}}{ZC_{L1}} \cdot sh(\gamma_{L1} \cdot L_{L1})$$

$$V_{1F} = V_{1R1} \cdot ch[\gamma_C \cdot (1-d) \cdot L_C] - I_{1R1} \cdot ZC_C \cdot sh[\gamma_C \cdot (1-d) \cdot L_C]$$

$$V_{1R1} = V_{1R} \cdot ch(\gamma_{L2} \cdot L_{L2}) - I_{1R} \cdot ZC_{L2} \cdot sh(\gamma_{L2} \cdot L_{L2}) \quad I_{1R1} = I_{1R} \cdot ch(\gamma_{L2} \cdot L_{L2}) - \frac{V_{1R}}{ZC_{L2}} \cdot sh(\gamma_{L2} \cdot L_{L2})$$

# Circuit for Faults in 1<sup>st</sup> Overhead Section

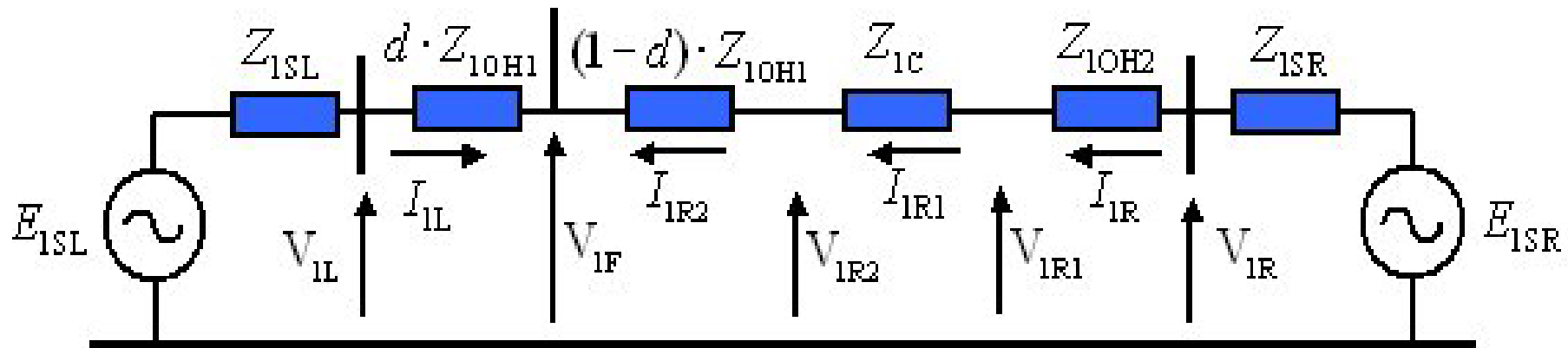

$$V_{1F} = V_{1L} \cdot ch(\gamma_{L1} \cdot d \cdot L_{L1}) - I_{1L} \cdot ZC_{L1} \cdot sh(\gamma_{L1} \cdot d \cdot L_{L1})$$

$$V_{1R2} = V_{1R1} \cdot ch(\gamma_C \cdot L_C) - I_{1R1} \cdot ZC_C \cdot sh(\gamma_C \cdot L_C) \quad I_{1R2} = I_{1R1} \cdot ch(\gamma_C \cdot L_C) - \frac{V_{1R1}}{ZC_C} \cdot sh(\gamma_C \cdot L_C)$$

$$V_{1F} = V_{1R2} \cdot ch[\gamma_{L1} \cdot (1-d) \cdot L_{L1}] - I_{1R2} \cdot ZC_{L1} \cdot sh[\gamma_{L1} \cdot (1-d) \cdot L_{L1}]$$

$$V_{1R1} = V_{1R} \cdot ch(\gamma_{L2} \cdot L_{L2}) - I_{1R} \cdot ZC_{L2} \cdot sh(\gamma_{L2} \cdot L_{L2}) \quad I_{1R1} = I_{1R} \cdot ch(\gamma_{L2} \cdot L_{L2}) - \frac{V_{1R}}{ZC_{L2}} \cdot sh(\gamma_{L2} \cdot L_{L2})$$



# RTDS Simulation

## MIXED LINE 220 kV

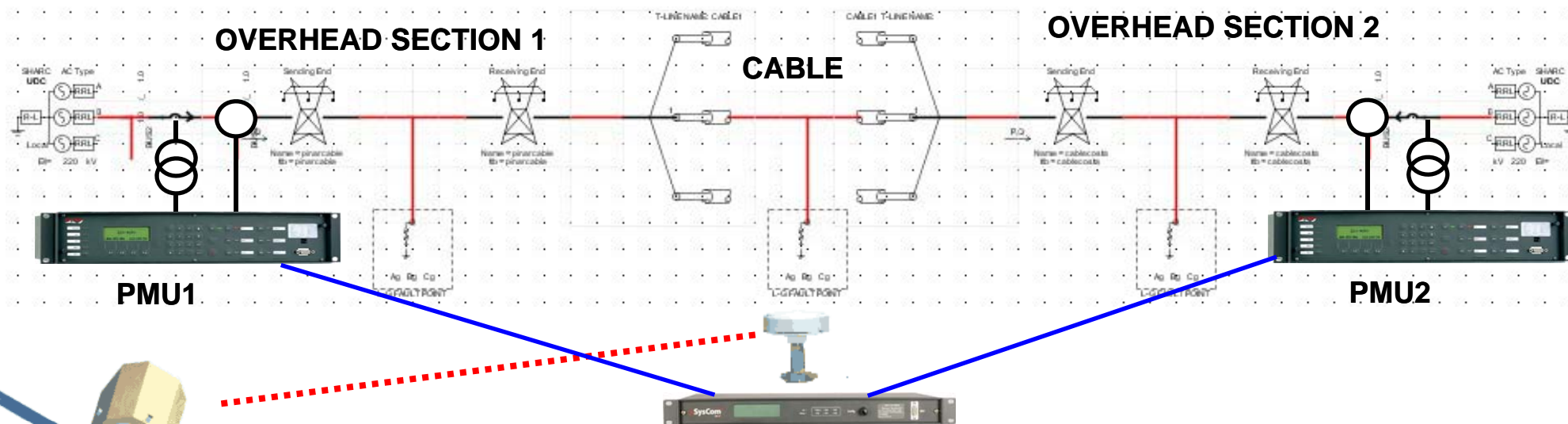

Overhead section 1 L=69.1 km	$z1 = 0.0717 + j \cdot 0.4135 \ \Omega/\text{Km}$ $z0 = 0.3029 + j \cdot 1.2471 \ \Omega/\text{Km}$ $y1 = j \cdot 2.8 \ \mu\text{S}/\text{Km}$ $y0 = j \cdot 1.97 \ \mu\text{S}/\text{Km}$
Cable L=3.9 km	$z1 = 0.0121 + j \cdot 0.1573 \ \Omega/\text{Km}$ $z0 = 0.1089 + j \cdot 0.0484 \ \Omega/\text{Km}$ $y1 = j \cdot 87.9 \ \mu\text{S}/\text{Km}$ $y0 = j \cdot 87.9 \ \mu\text{S}/\text{Km}$
Overhead section 2 L=12.8 km	$z1 = 0.0718 + j \cdot 0.4144 \ \Omega/\text{Km}$ $z0 = 0.3036 + j \cdot 1.2493 \ \Omega/\text{Km}$ $y1 = j \cdot 2.8 \ \mu\text{S}/\text{Km}$ $y0 = j \cdot 1.98 \ \mu\text{S}/\text{Km}$

# Results with PMUs errors (I)

## INFLUENCE OF FAULT LOCATION

AG 10 ohms

FAULTS IN OVERHEAD SECTION 1		
FAULT LOCATION	LOCATION ALGORITHM 1	LOCATION ALGORITHM 2
10%	10.037%	9.827%
20%	19.812%	19.990%
30%	29.923%	30.057%
40%	39.996%	40.172%
50%	49.803%	50.084%
60%	59.980%	60.139%
70%	70.191%	70.105%
80%	79.718%	79.861%
90%	90.042%	90.187%

FAULTS IN THE CABLE		
FAULT LOCATION	LOCATION ALGORITHM 1	LOCATION ALGORITHM 2
10%	14.256%	15.766%
20%	25.231%	26.320%
30%	32.489%	24.686%
40%	39.574%	37.963%
50%	51.527%	45.603%
60%	68.502%	66.456%
70%	77.820%	76.968%
80%	82.341%	83.563%
90%	93.042%	94.187%

■ 11% error relative to  $Z_{cable} \leftrightarrow 0.239\%$  error relative to  $Z_{overhead 1}$

# Results with PMUs errors (II)

## INFLUENCE OF FAULT RESISTANCE

FAULTS IN OVERHEAD SECTION 1				
FAULT TYPE	FAULT LOCATION	FAULT RESISTANCE (ohms)	LOCATION ALGORITHM 1	LOCATION ALGORITHM 2
AG	20%	10	19.812%	19.990%
BCG	20%	10	19.823%	19.924%
AG	20%	50	20.161%	20.187%
BCG	20%	50	20.173%	20.231%
AG	80%	10	79.718%	79.861%
BCG	80%	10	79.633%	79.697%
AG	80%	50	79.675%	80.041%
BCG	80%	50	79.814%	80.237%

# Results with PMUs errors (III)

## INFLUENCE OF FAULT TYPE

FAULTS AT 20% OF OVERHEAD SECTION 1		
FAULT TYPE	LOCATION ALGORITHM 1	LOCATION ALGORITHM 2
AG	19.812%	19.990%
BG	19.862%	20.168%
CG	20.265%	20.373%
AB	19.851%	20.013%
BC	20.060%	20.110
CA	20.275%	19.874%
ABG	20.256%	19.855%
BCG	19.823%	19.924%
CAG	19.836%	19.960%
ABC	20.005%	20.050%

FAULTS AT 80% OF OVERHEAD SECTION 1		
FAULT TYPE	LOCATION ALGORITHM 1	LOCATION ALGORITHM 2
AG	79.718%	79.861%
BG	79.981%	80.206%
CG	80.219%	80.057%
AB	80.186%	80.162%
BC	80.237%	80.213%
CA	80.257%	80.224%
ABG	80.225%	80.201%
BCG	79.633%	79.697%
CAG	80.256%	80.233%
ABC	80.040%	80.110%



# Synchronization Errors



**10<sup>0</sup> error between currents    10<sup>0</sup> error between voltages**

FAULT LOCATION	ADDITIONAL ERROR ALGORITHM 1	ADDITIONAL ERROR ALGORITHM 2
20%	0.024%	-0.182%
40%	0.517%	-0.169%
60%	1.173%	-0.06%
80%	1.615%	0.02%

FAULT LOCATION	ADDITIONAL ERROR ALGORITHM 1	ADDITIONAL ERROR ALGORITHM 2
20%	16.245%	0.021%
40%	15.283%	0.003%
60%	14.461%	0.025%
80%	14.425%	0.007%

- Need for accurate synchronization between voltages for algorithm 1 → GPS
- Algorithm 2 allows higher synchronization errors

# Current Transformer Errors

**+3%  $I_{\text{local}}$  / -3%  $I_{\text{remote}}$**

FAULT LOCATION	ADDITIONAL ERROR ALGORITHM 1
20%	-0.791%
40%	-1.425%
60%	-1.75%
80%	-1.742%

**+2°  $I_{\text{local}}$  / +2°  $I_{\text{remote}}$**

FAULT LOCATION	ADDITIONAL ERROR ALGORITHM 1
20%	0.230%
40%	0.377%
60%	0.442%
80%	0.426%

- Calibration of PMUs with the CT error curves

# Voltage Transformer Errors

**+3%  $V_{\text{local}}$  / -3%  $V_{\text{remote}}$**

FAULT LOCATION	ADDITIONAL ERROR ALGORITHM 1
20%	6.343%
40%	9.457%
60%	10.757%
80%	10.198%

**+2%  $V_{\text{local}}$  / +2%  $V_{\text{remote}}$**

FAULT LOCATION	ADDITIONAL ERROR ALGORITHM 1
20%	7.393%
40%	7.452%
60%	7.363%
80%	7.226%

- Calibration of PMUs with VTs error curves
- Algorithm 2 will reduce the errors



# Oscillations Monitoring



# Oscillations Monitoring

- Interarea oscillations in the UCTE due to system enlargement (around 0.2 Hz):
  - Non planned load flows
  - Loss of stability risk in case of poorly damped oscillations
- Wind power growth
  - Wind volatility
  - Response to voltage dips
  - Displacement of conventional generators with PSS
- Need to improve knowledge of system dynamic behaviour



# PMUs Role

- Pilot project on REE: PMUs measurements to determine characteristics of oscillations in Morocco-Spain interconnection:
  - Frequency
  - Amplitude
  - Damping
  - Phase
- PMUs measuring power in one end of the Spain-Morocco double circuit:
  - 50 synchrophasors / sg



# Aims

- Damping problems identification
- PSS retuning on power stations
- Model validation for different conditions
- Development of defense plans against unstable oscillations



# Conclusions



# Conclusions (I)

- **Line impedances calculation based on PMUs**
  - Can provide better results than traditional methods, based on the line constants
  - PMUs require high accuracy in the synchronization and need to be calibrated with instrument transformers errors
  - Positive sequence impedance calculation based on fault / pure fault values:
    - Allows higher synchronization errors between the voltages
    - Allows higher VT errors



# Conclusions (II)

- **Fault locator for mixed lines based on PMUs**
  - Can be used as a protection scheme without devices required at both ends of the cable
  - For the faults injected, the algorithm based on pure fault values:
    - Allowed higher synchronization errors between the voltages
    - Allowed higher VT errors



# Conclusions (III)

- Oscillations monitoring based on PMUs improves knowledge of system dynamic behaviour



# Questions?

